

Installation and assembly instruction v4

Spider

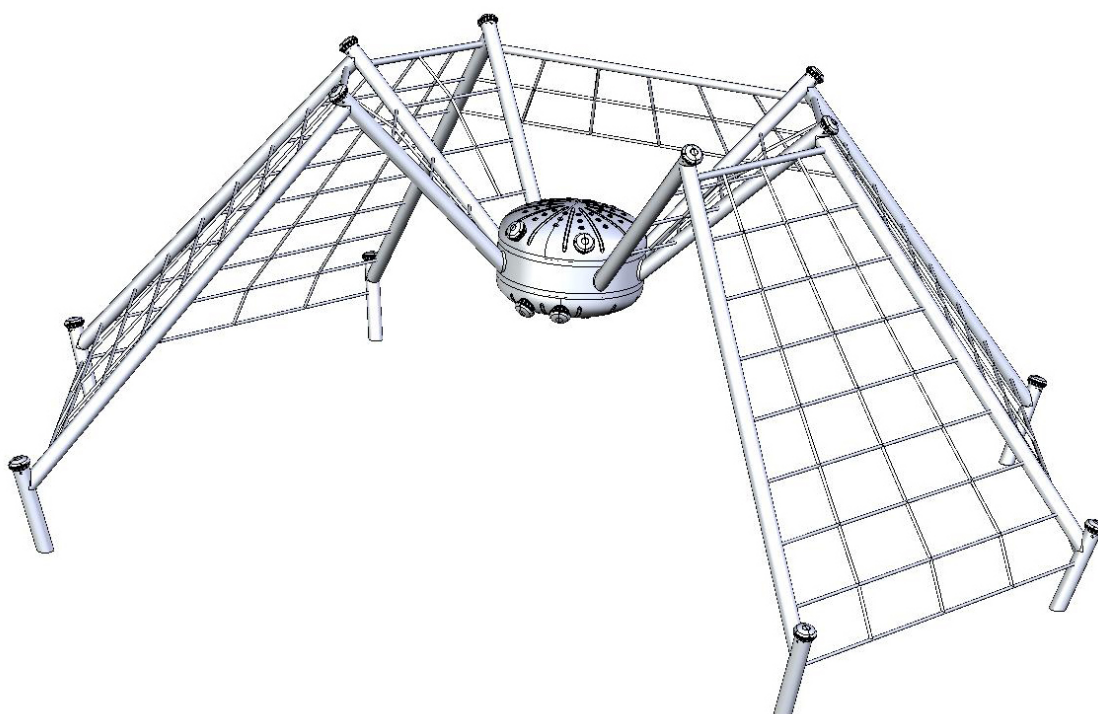

**play[®]
alive**

1. Content

2. Component overview

- 2.0 Content of transport case
- 2.1 - 2.8 Component overview

3. Site of spider construction

- 3.1 Maximum length of power cable
- 3.2 Measurements of impact area
- 3.3 Foundations

4. Mounting of steel construction

- 4.1 Support of the center ring
- 4.2 Mounting of rear left leg (Leg C)
- 4.3 Mounting of rear right leg (Leg D)
- 4.4 Mounting of two middle legs (Leg B + E)
- 4.5 Mounting of two front legs (Leg A + F)

5. Mounting of net

- 5.1 Mounting of side nets
- 5.2 Mounting of top net
- 5.3 Mounting of rear net

6. Electronics

- 6.1 Pulling of devicenet cable
- 6.2 Pulling cables inside the legs
- 6.3 Mounting of satellites placed in the legs
- 6.4 Mounting of satellites on the body of the Spider

7. Plastic parts

- 7.1 Mounting of plastic shells
- 7.2 Mounting of plastic bracket

8. Verifying dimensions / casting foundations

- 8.1 Verifying dimensions
- 8.2 Casting the concrete

9. For the electrician

- 9.1 Installing cabinet with power outlet for PlayAlive power supply
- 9.2 Services, PC connection
- 9.3 Electrical specifications

10. Start up

- 10.1 Start up the system
- 10.2 Select and start game
- 10.3 Reset the game
- 10.4 Idle mode
- 10.5 Adjust volume if needed

11. Appendix

- 11.1 General introduction to PlayAlives Technology Platform
- 11.2 Conduit pipes and PlayAlive technology
- 11.3 Games

2.0 Content of transport case

The spider product arrives in a big wooden box / transport case. The box contains the steel structures as well as eight smaller boxes. The contents are specified below.

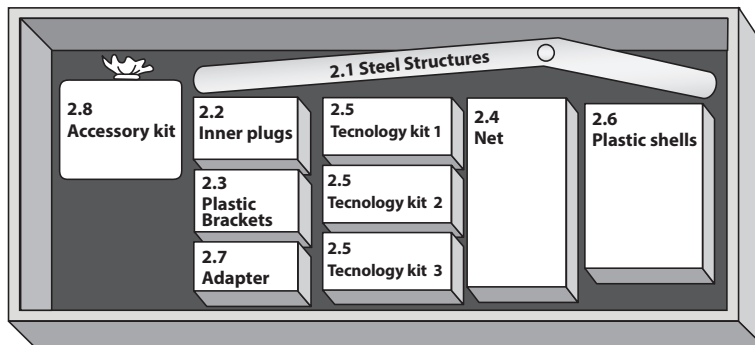

Important!

Check the packing list.
– Due to model variations, actual content may differ from the illustration

2.1 Steel structures (placed in transport case) (P00091)

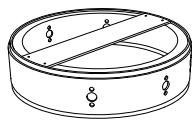

1 x Center ring
P-MA002



1 x Front left leg
(leg A)
P-MA003



2 x Middle leg
(leg B + E)
P-MA004



1 x Rear left leg
(leg C)
P-MA005



1 x Rear right leg
(leg D)
P-MA006



1 x Front right leg
(leg F)
P-MA007



1 x Rear connector tube
P-MA010



4 x Connector tube
(for side mounting)
P-MA011



12 x Casting anchor
P00115

2.2 Inner plugs for connector tubes (P00094)



8 x Inner plugs A
(for connctor tubes)
P-MM016



2 x Inner plugs B
(for connctor tubes)
P-MM017



20 x Self tapping screw 4 x 20 mm
P00142

2.3 Plastic brackets (P00083)

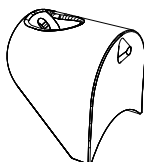

6 x Plastic bracket
P-MP015



6 x Button Head M6 x 16 mm
P00009

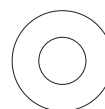

6 x Washer M6
P00141

2

Component overview

2.4 Net (P00092)



117 x Shackles
P00122

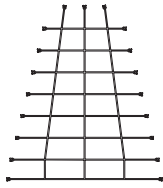

4 x Side net
P-MZ001

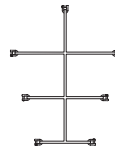

4 x Top net
P-MZ003

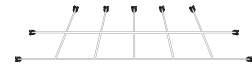

1 x Rear net
P-MZ002

2.5 Tecnology kit 1-3 (P00124)



3 x 2 m Data cable
P00254



7 x 3,5 m Data cable
P00255



5 x 7 m Data cable
P00263



1 x Devicenet cable 33 m
power- and data cable
P00258



1 x Termination
P00252

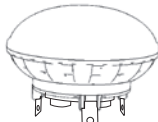

16 x Satellite
P00020



48 x Countersunk screw
M5 x 12 mm
P00077

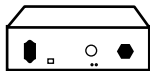

1 x Power supply
(IPSU)
P00251



1 x 230 AC cable
(EU + UK)

2.6 Plastic shells (body of Spider) (P00075)



1 x Top plastic shell
P-MP011



1 x Bottom plastic shell
P-MP012



22 x Buttonhead M5 x 12 mm
P00076

2.7 Satellite adapters for body of Spider (P00079)

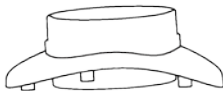

4 x External adapter
P-MM037



4 x Inner adapter
P-MM038



24 x Buttonhead M5 x 16 mm
P00007

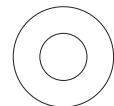

24 x Washer M5
P00143

2.8 Accessory kit (P00095)



1 x Manual
P00144

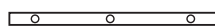

40 x Rubber strips
P00117



1 x Glue
P00011



1 x Grease
P00010



1 x Drill 3.5mm
P00119



TX 25
P00005

3

Site of Spider construction

3.1 Maximum length of power cable

For details on cable pipes see the technical details in section 11.

Tip:

All legs are prepared for cables to be pulled inside the legs.

Important!

Remember pull wire in cable pipe.

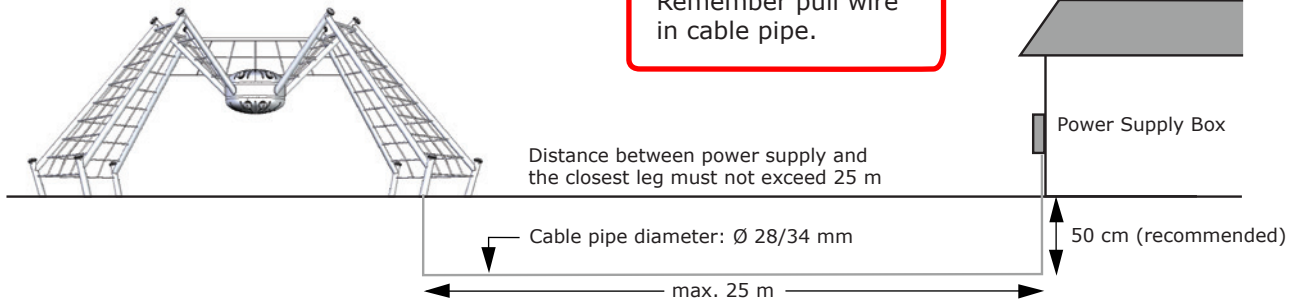

3.2 Measurement of impact area

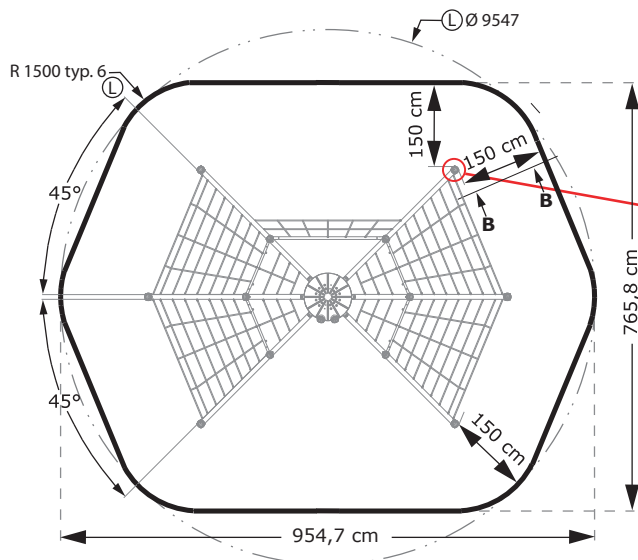

Tip:

Verify dimensions: Distance from the center of the Spider to the edge of the impact area = min. 480 cm measured parallel to any leg.

3.3 Foundation

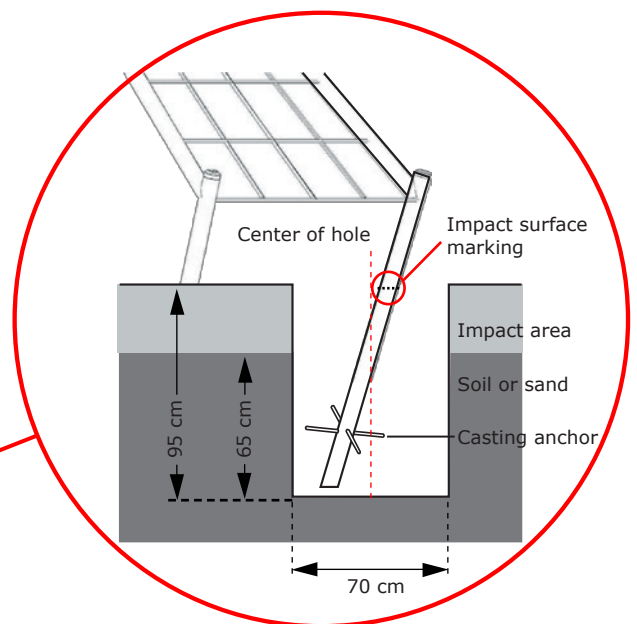
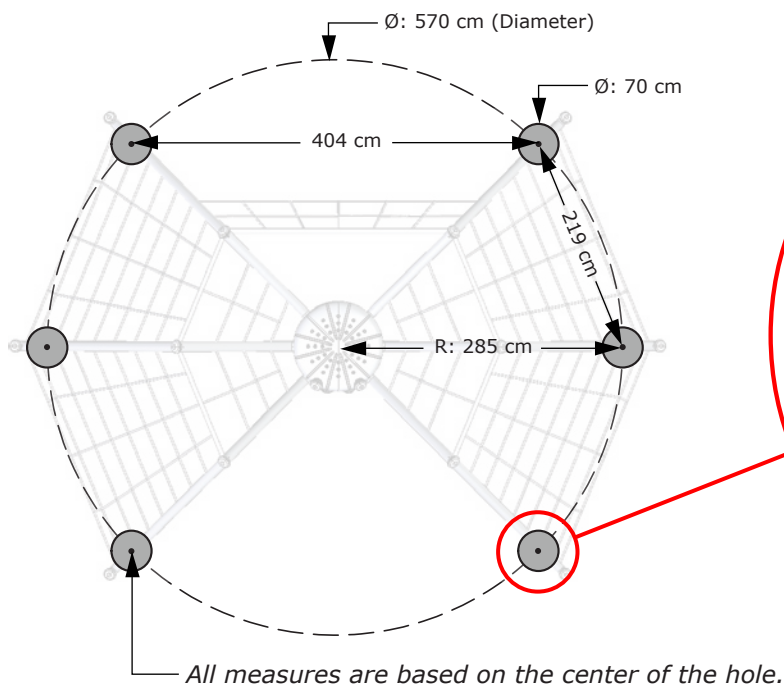

Size of foundations

4

Mounting of steel construction

4.1 Support of the center ring

The installation will become easier by using a support table for correct placing and leveling of the center ring.

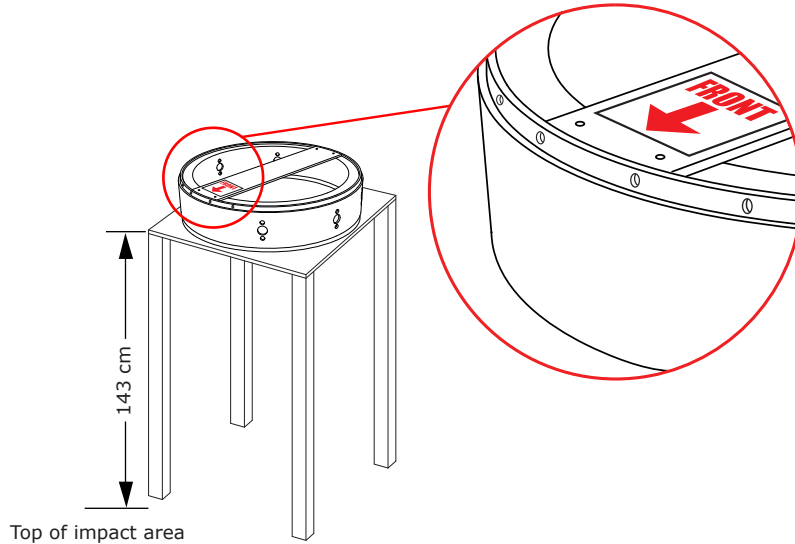

Important!

The 4 narrowly placed holes on the center ring should face forward.

Important!

Note that there are 5 different legs. It is important that they are assembled correctly in order for nets and connector tubes to be mounted. Check label on the legs.

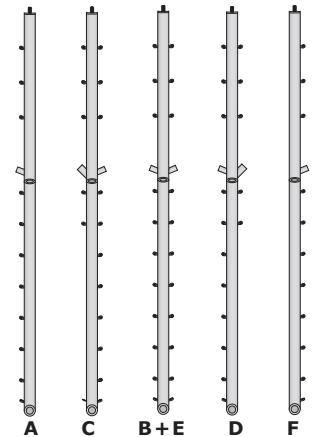

4.2 Mounting of rear left leg (Leg C)

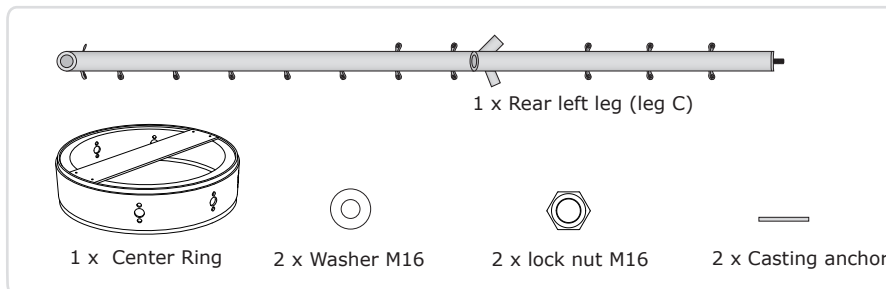

Important!

All bolts, nuts and threads must be lubricated with the supplied grease.

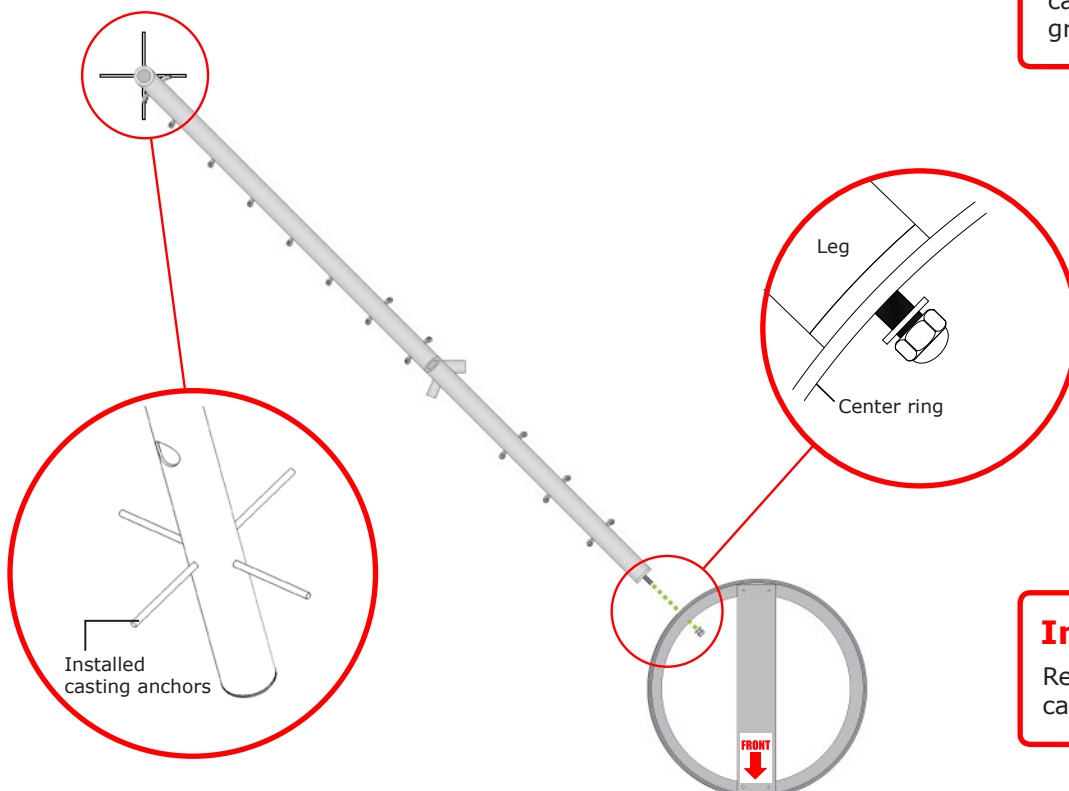

Important!

Remember to install the casting anchors.

4.3 Mounting of rear right leg (Leg D)

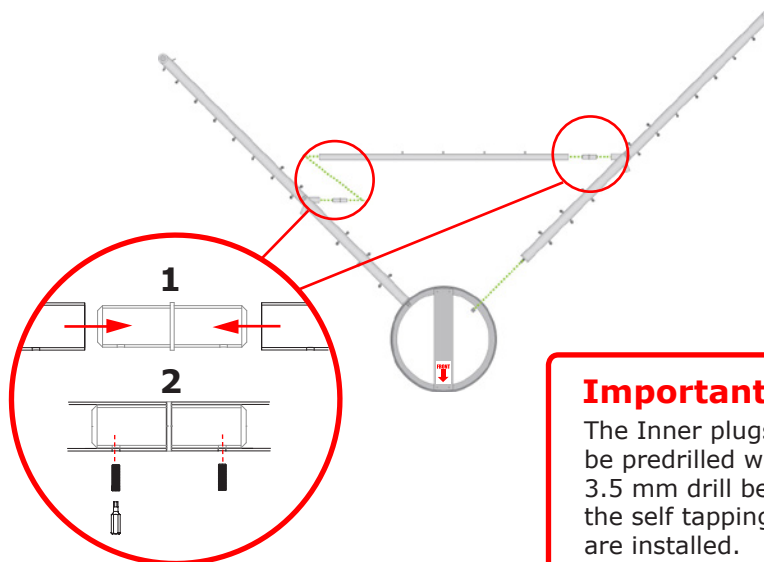
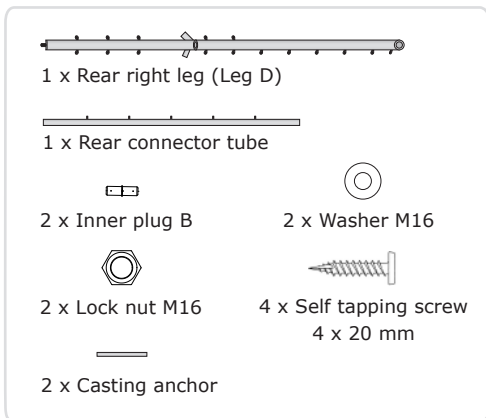

Important!
The Inner plugs must be predrilled with a 3.5 mm drill before the self tapping screws are installed.

4.4 Mounting of two middle legs (Leg B + E)

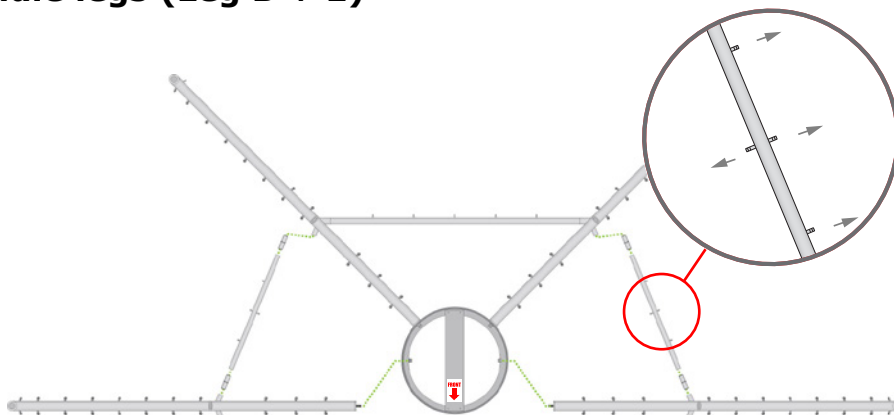
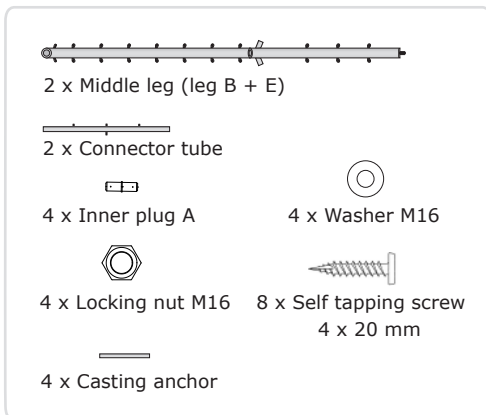

4.5 Mounting of two front legs (Leg A + F)

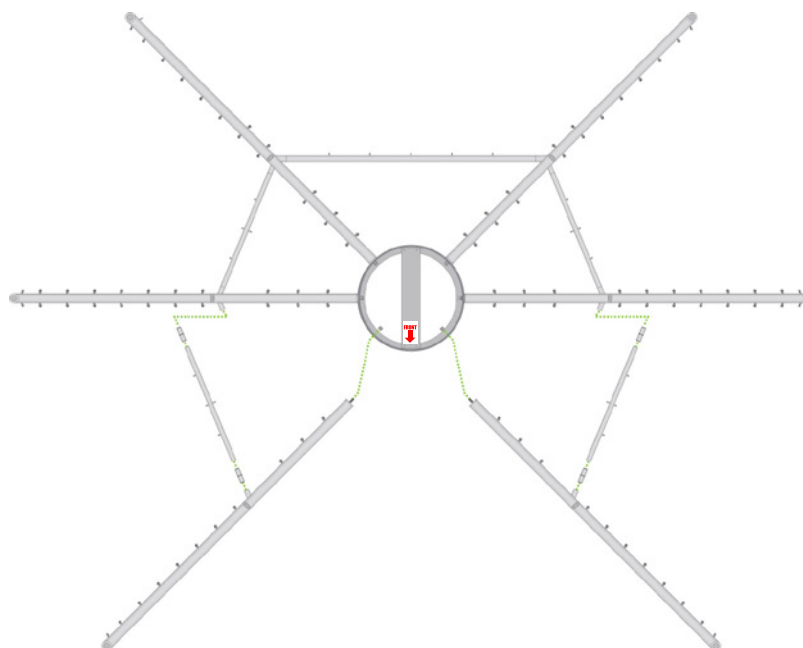
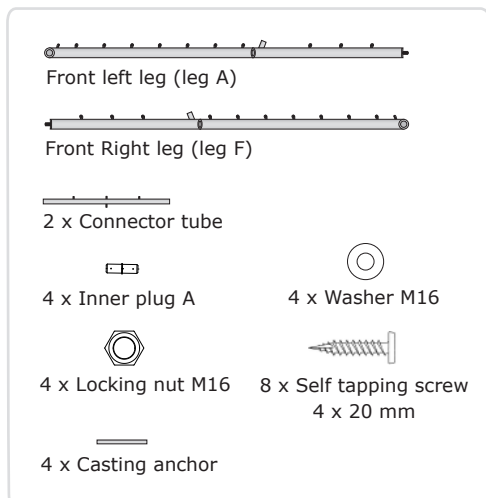

5

Mounting of nets

5.1 Mounting of side nets

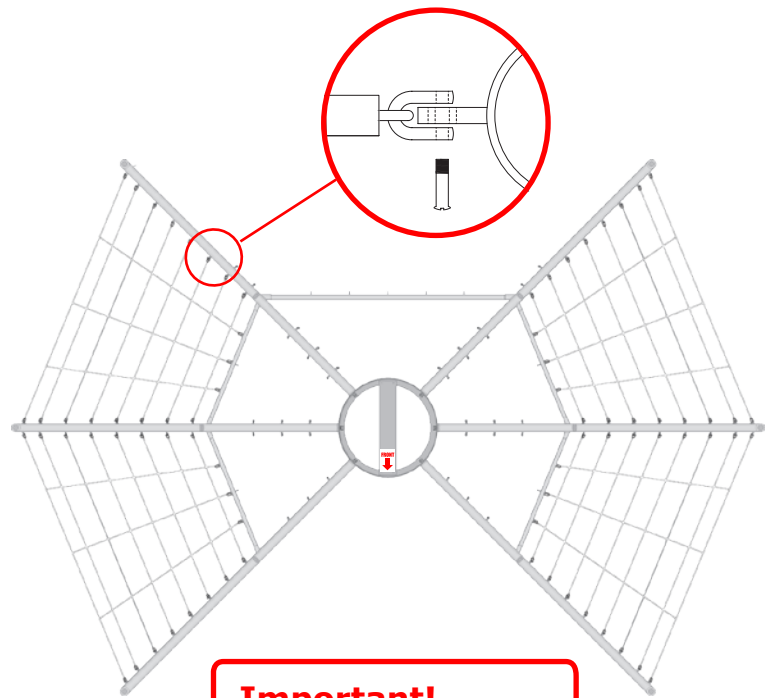
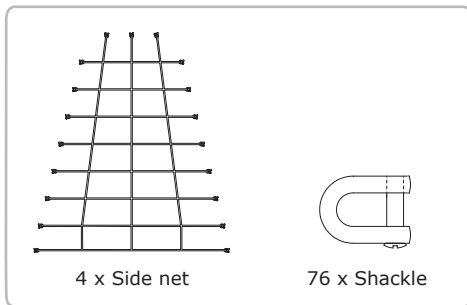

Important!

Shackles must be secured with the supplied glue.

5.2 Mounting of top net

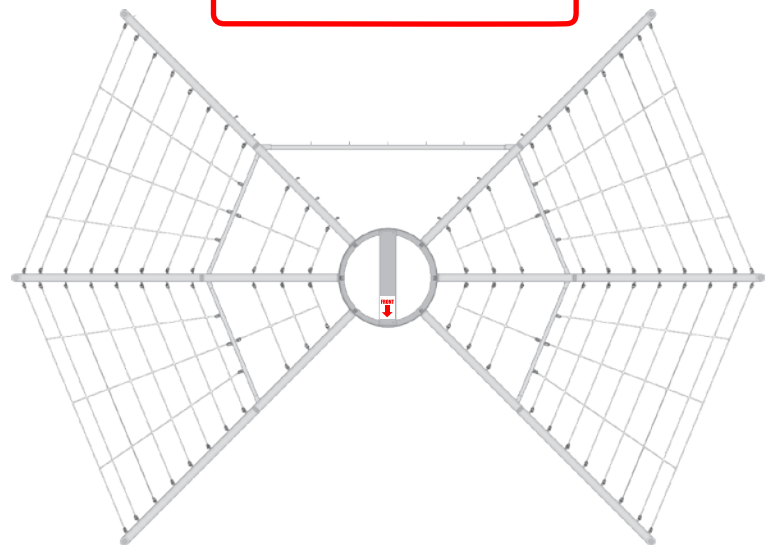
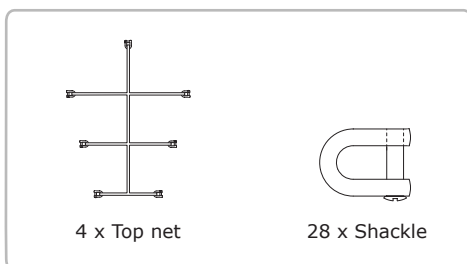

5.3 Mounting of rear net

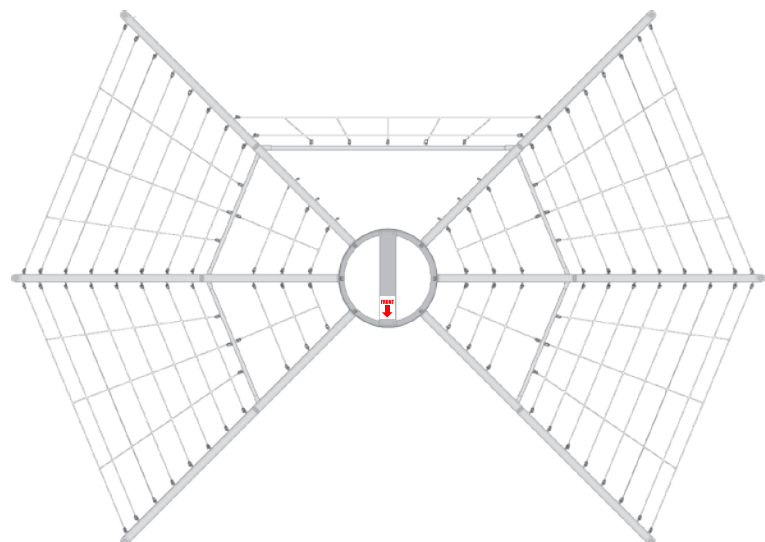
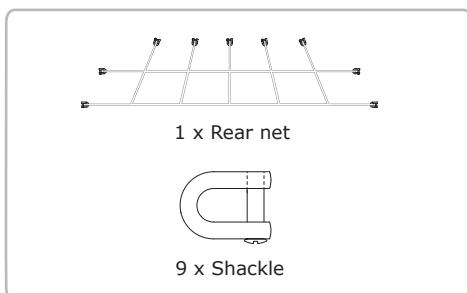

6.1 Pulling of devicenet cable

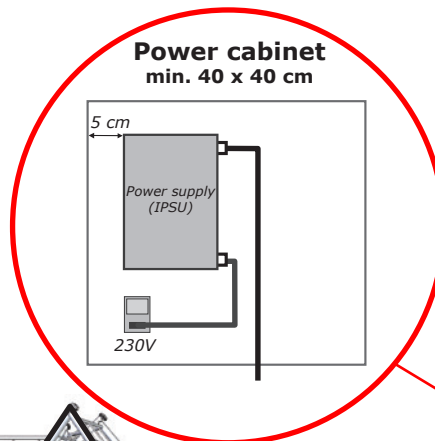
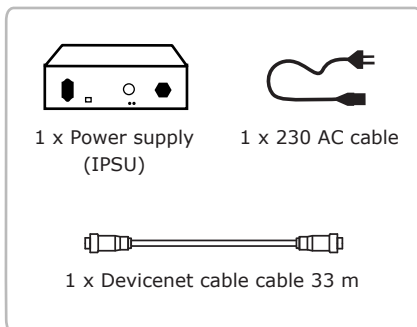

Important!

The connectors must be kept dry and free from dirt, sand and soil. The cables must be handled with care and must never be pulled in the plugs.

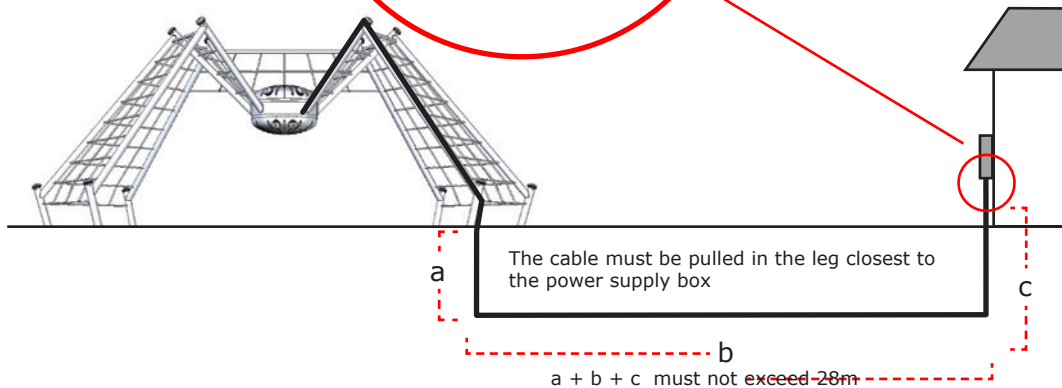

6.2 Pulling cables inside the legs

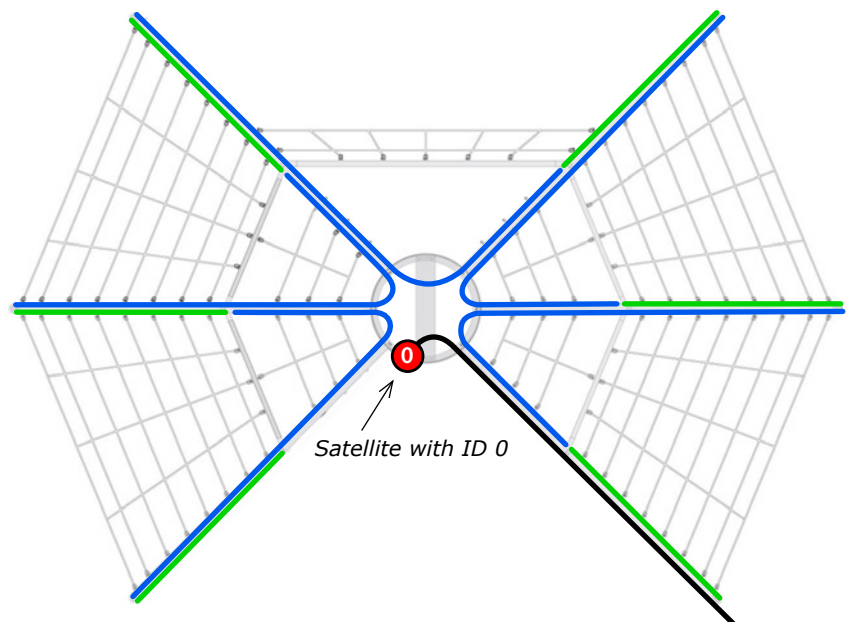
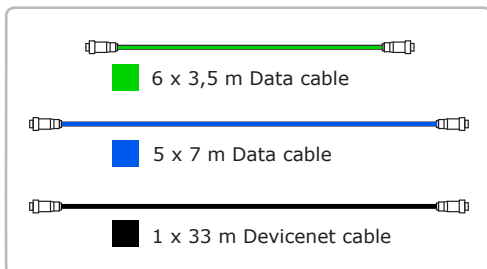

Tip:

When installing the cables inside the tubes of the spider, it can be of advantage to pull them two at a time. This makes them less flexible and easier to pull.

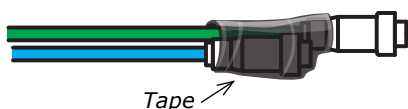

- Cable from knee to foot (3,5 m)
- Cable from foot to neighbour knee (7 m)
- Devicenet cable from power supply (IPSU) to satellite 0

6.3 Mounting of satellites placed in the legs

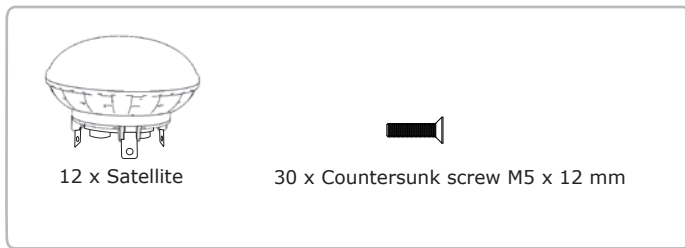

Important!

All satellites have an ID number which can be found on the bottom of the satellite. The ID-number determines where the satellite must be placed on the Spider. (see the illustration)

Satellites must be wired using serial connection – Please, carefully follow the illustration below.

- Cable from knee to foot (3,5 m)
- Cable from foot to neighbour knee (7 m)
- Cable for connecting the eyes (2 m)
- Devicenet cable for power supply (IPSU)

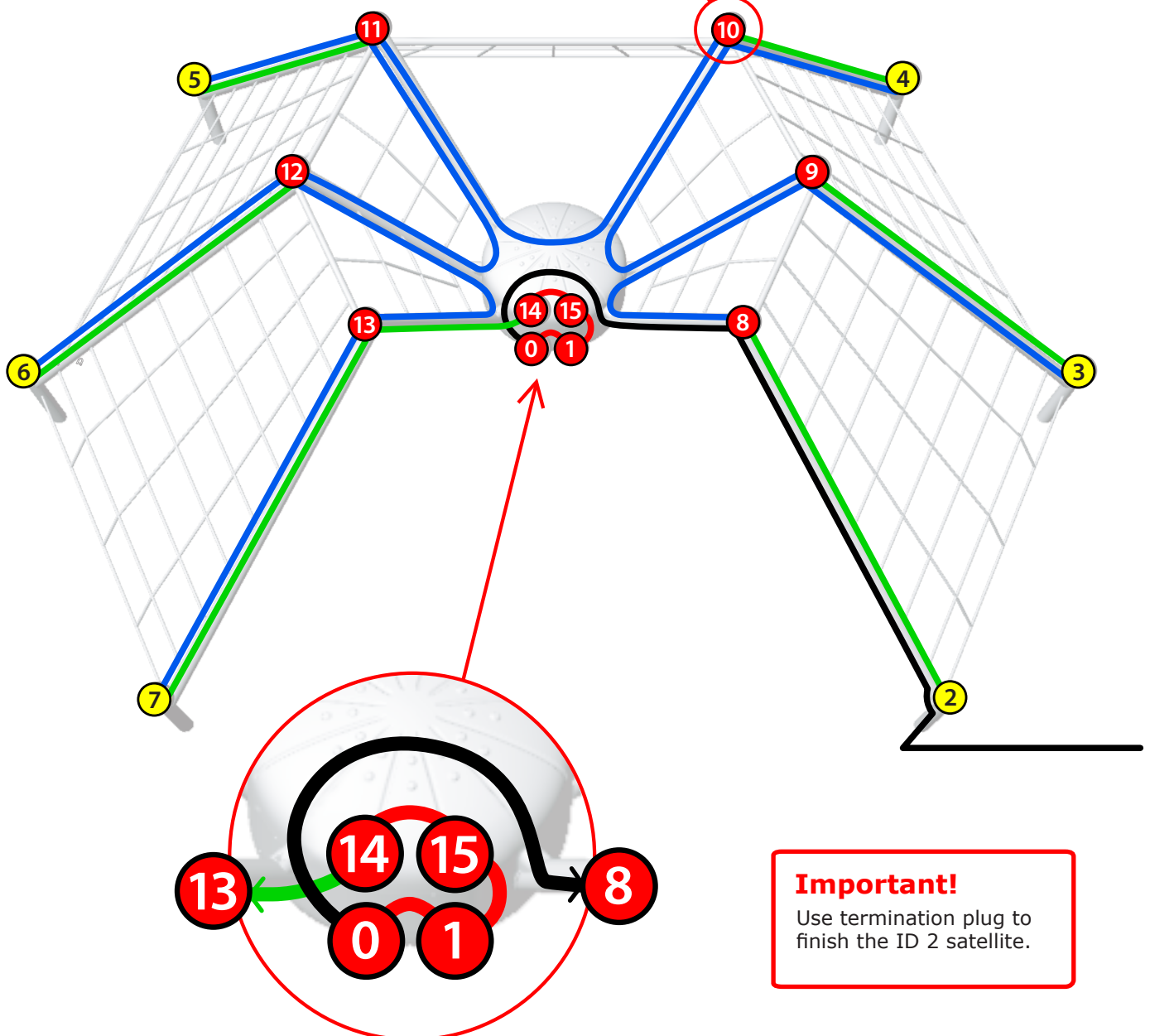
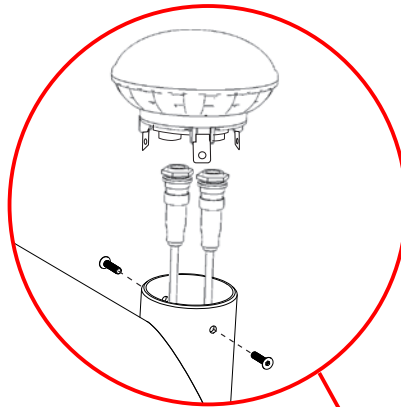

Important!

Use termination plug to finish the ID 2 satellite.

6.4 Mounting of satellites on the body of the Spider

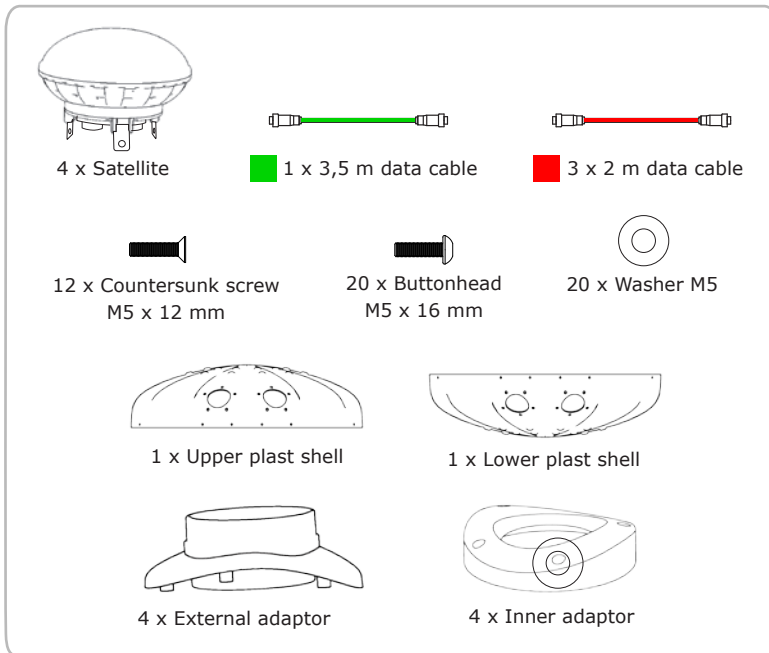

Important!

Satellites and adapters must be assembled so the logo is oriented correctly.

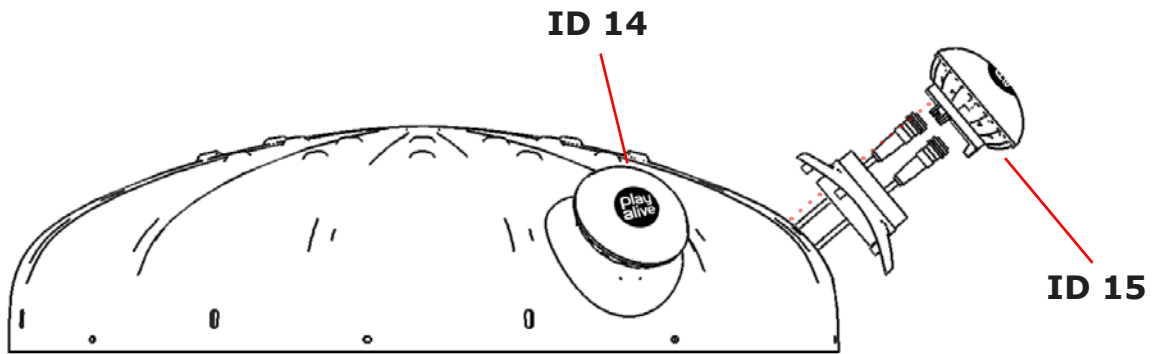
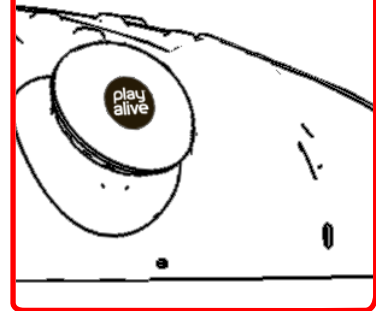

Upper plast shell

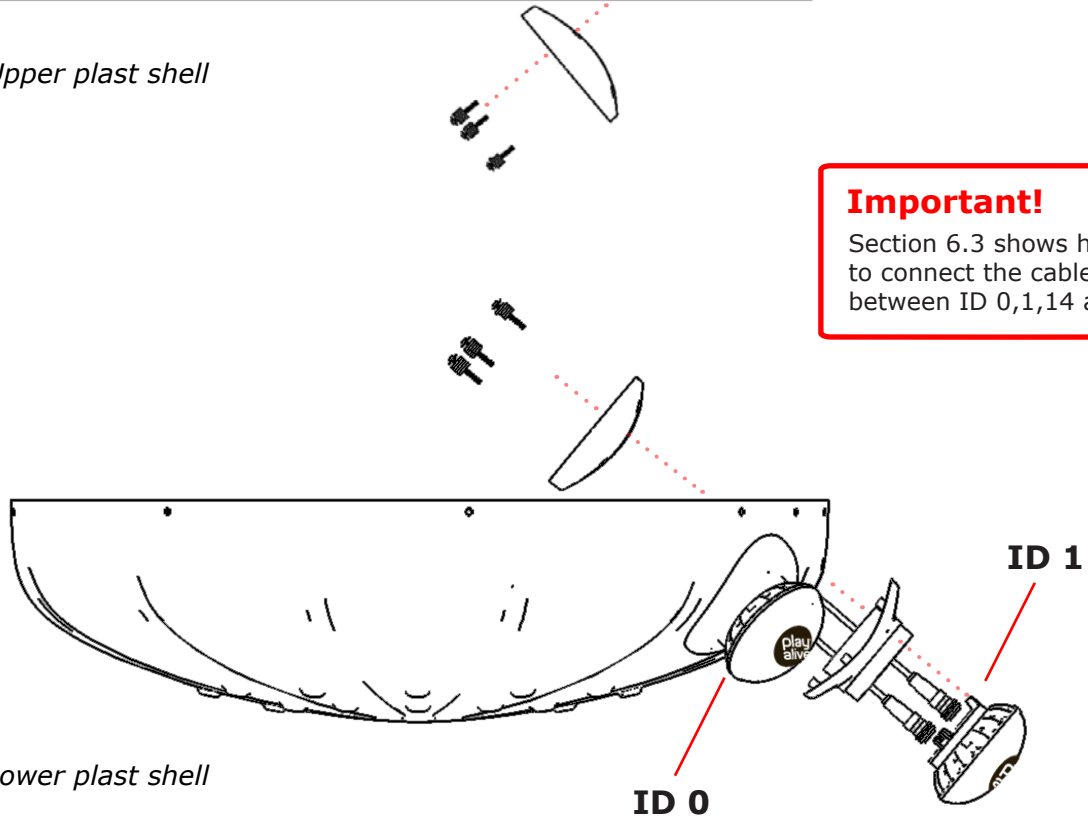

Lower plast shell

Important!

Section 6.3 shows how to connect the cables between ID 0,1,14 and 15.

7.1 Mounting of plastic shells



20 x Buttonhead M5 x 12 mm

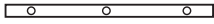

40 x Rubber strips

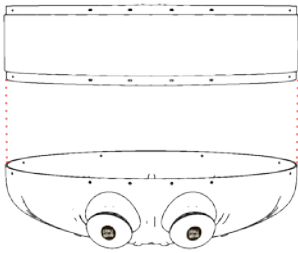

Lower plastic shell is mounted on the center ring.

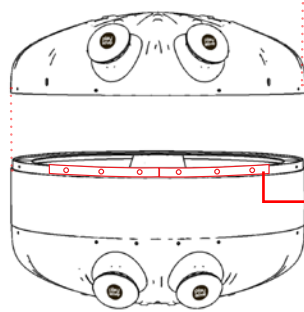

Upper plastic shell is mounted on the center ring.

Important!

Remember to lubricate the screws with the supplied grease.

Important!

Due to manufacturing tolerances on the plastic shells, it may be necessary to install rubber strips between the center ring and plastic shell.

Tip:

When installing the rubber strips, start at the front as shown in the illustration.

7.2 Mounting of plastic brackets

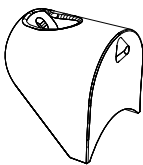

6 x Plastic brackets



6 x Buttonhead M6 x 16 mm



6 x Washer M6

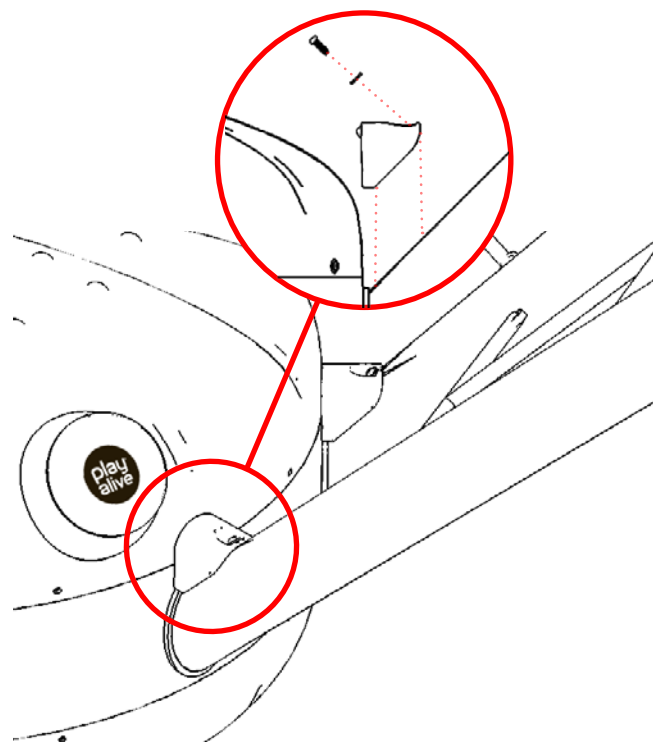

8.1 Verifying dimensions

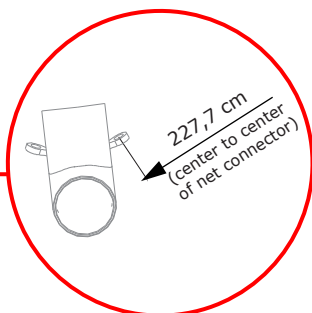
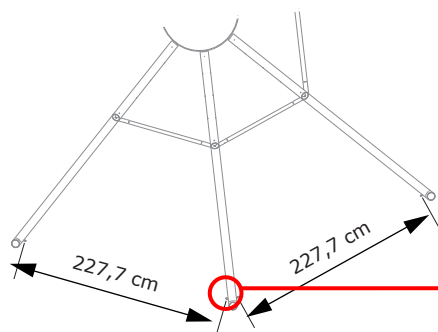
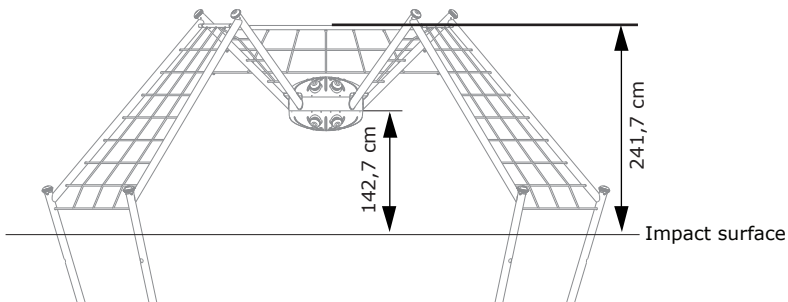
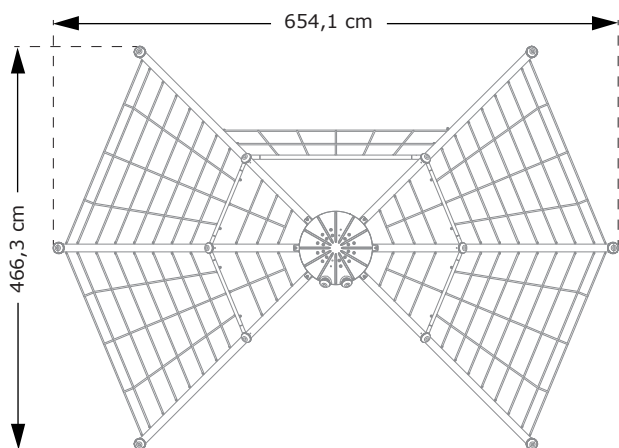

Important!

Remember to verify the dimensions before casting the concrete.

Important!

To ensure the correct distance between the legs, a temporary spacer may be placed as illustrated.

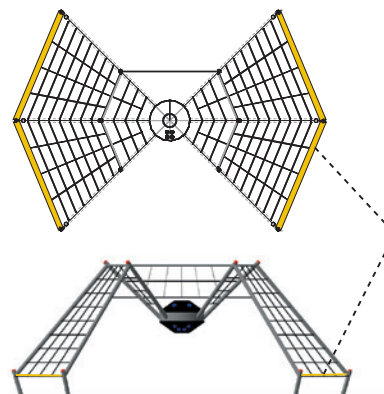

8.2 Casting the concrete

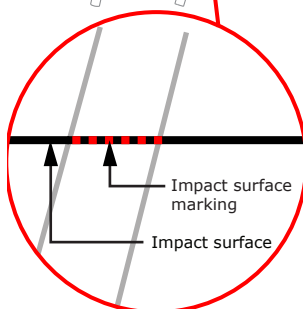
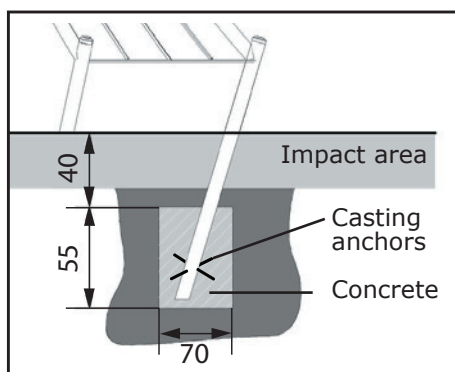
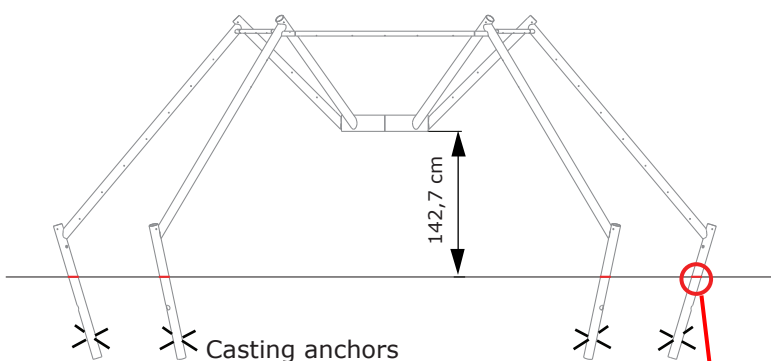

Important!

Verify that the casting anchors are in the right position.

Tip:

After legs have been founded with concrete, the play area must be blocked off with a ribbon marker. The equipment can be used 24 hours after completion of the foundations.

9.1 Installing cabinet with power outlet for PlayAlive power supply

PlayAlive spider uses a 230VAC -> 24VDC power supply. A cabinet containing at least 1 pcs 230V AC power outlet must be installed. Ground connection needed. The cabinet must be installed by the customer's electrician. The cabinet can be placed indoor or outdoor depending on the customer's request.

IMPORTANT: When identifying the proper location of the power supply cabinet it is crucial to note that the 24V DC power cable has a maximum length of 33 meters. The 33-meter cable should cover the distance from the Spider's head, through the legs, distance in the ground and connection in the cabinet!

Typical specifications for the cabinet:

Dimensions: 400 x 400 x 250 mm (Power supply dimensions: 263 x 183 x 91 mm).
Vandalism proof metal cabinet with at least 1 key lock.
At least 1 (preferable 2-3) socket(s) with ground installed in the cabinet.

Cabinet with power outlet
min. 40 x 40 cm

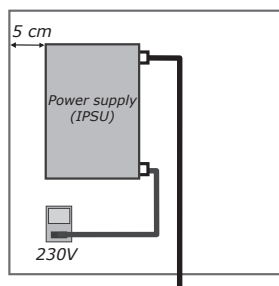

Optional: A timer controlling the electricity (power on/off) can be added to the cabinet. Please see illustration of standard timer that can be installed in a 110 V/230 V power outlet. The timer need to be sourced locally. When applying a timer the power can be switched off for example at night time.

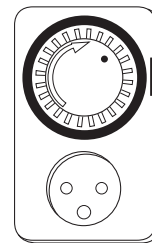

The optional timer could look like this.

9.2 Services, PC connection

Services and access to a PC should only be done by PlayAlive trained staff.

9.3 Electrical specifications

Type: PlayAlive Spider

Input: 100-240VAC, 50/60Hz, 5.4 A

Secondary: 24VDC, 0-13,4 A short circuit protected

Power Consumption: Max 240W

10 Start up

10.1 Start up the system

Turn the power on at the IPSU. The satellites boot up and after few minutes the power supply box should indicate two green lights. The system is now ready to play.

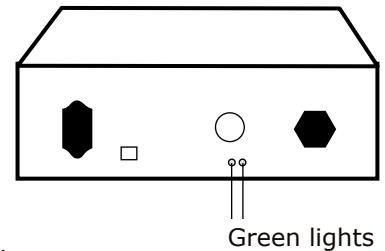

10.2 Select and start game

1. Power must be turned on
2. If satellites are flashing a color the game is in idle mode and ready for game selection and start
If satellites are in "sleep" mode touch any satellite to make the satellites ready for game selection and start
3. Go to the body of the Spider and look at the two satellites in the lower part
4. Use the left satellite (seen from the players view) to toggle between the three different games. Each touch on the left satellite will show a new game color on the right satellite
5. Touch the right satellite when the desired game it highlighted
6. Game will start

10.3 Reset the game

Place your hand app. 5 seconds on the satellite with **ID 1** (placed at the right corner of the spiders body.) The game is terminated and the satellite will toggle between the 3 different game colors where after a new game can be selected.

10.4 Idle mode

In idle mode all satellites lights up individually and can be used individually. This mode is often a hit for minor children and designed to create awareness.

The platform will go in idle mode if games are not selected. The system will turn off and only wake up every now and then and show colors to attract attention. Touching any satellite will bring the system back and you will be able to select games at the select game console.

10.5 Adjust volume if needed

To adjust the volume, follow this procedure:

1. Turn off power
2. Turn on power
3. Wait until the system is ready for game selection (sat. 0 and 1 will be in "scroll and a selection" mode)
4. Touch and hold sat. 00 (lower left satellite in body) - not later than 30 seconds after the scroll and selection menu appears after restart
5. Touch sat. 01 (lower right satellite) for a short while (when still holding sat. 00)
6. The system will respond "set volume" - release the hand from sat. 00
7. Touch sat. 01 for volume adjustment
8. For each touch on sat. 01 a sound will be played and volume level will be indicated on the satellite
9. When the preferred volume level has been reached sat. 00 must be touched for storage
10. Volume has been adjusted and stored

NOTE: It is rather important to have a certain sound level in order to experience the full joy of the individual PlayAlive activities.

If you have been able to conduct the elements as described at section 10.1 - 10.3 the PlayAlive site has been successfully installed.

Thanks for your effort installing another PlayAlive product.

11.1 General introduction to PlayAlives Technology Platform

The PlayAlive system is an interactive system. The technology elements communicate with each other and thereby make it possible to realize activities for all ages.

The visible part of the installation is the “satellites”. The satellites are intelligent units that contain light, sound, touch sensor, and communication. They act as the user interface to the system. Cables connected to satellites supply them with power and communication.

IMPORTANT: BE CAREFUL WHEN HANDLING THE PARTS.

The PlayAlive technology elements are highly advanced electronics. Despite the fact that they are very robust after installation, they can easily be damaged before or during installation if not treated correctly.

NOTE: ALL PARTS ARE DESIGNED TO FIT TOGETHER WITHOUT THE NEED OF USING FORCE.

11.2 Conduit pipes and PlayAlive technology

When using flexible cable pipes it is important to ensure that the minimum bending radius complies too the following:

For our devicenet cables, we recommend 28/34 mm flexible cable pipe / conduit pipe with double walls for easy pulling of the cables. Please note that low cost cable pipes are very soft and therefore very easy to bend in inappropriate radiuses – they are not recommended!

It is further recommended to place covers over the ends of the cable pipes during the period from installation of the pipes to installation of the electronics to avoid water in the pipes.

When installing the cable pipes it is recommended to ensure that care is taken to ensure that the pulling string in the pipes are kept available. It makes pulling the cables a lot easier. If this is not possible, then we recommend that you use vacuum (ex. a vacuum cleaner) to suck a pulling string through. It has proven easier than other methods.

In some cases it is possible to push the cable through the pipes without other help. In cases where this is not possible, it is recommended to use a pulling string.

Please be aware that the PlayAlive cables are not designed to be pulled in the connectors. When pulling the cables please make sure that you pull the cable and not the connector.

Important!

Remember devicenet cables in conduit pipe. Conduit pipe needs to be sourced locally.

11.3 Games

Please see the instructions for the different games below:

Hot & Cold	<p>Two persons or two teams play each other. Red against blue team. The team who hits the most satellites during 30 seconds will win.</p> <p>High energy, fun and competition – and simple.</p>
Speedy	<p>Hit as many satellites as possible during 30 seconds and beat the high score.</p> <p>High energy and improve your high score. Fun for many kids at the same time.</p>
ChaosTennis	<p>Beat your best friend or dad in a game of Squash. The game is adaptive and will adjust speed to level of the players.</p> <p>High speed game for two or four players. Length of the game depends on the players ability.</p>
Free Play	<p>Each satellite will have its own play mode with funny sounds, music tunes and light creation. Will cease when games are started.</p>
Lightshow	<p>After 2 minutes of no activities all satellites will go in sleep mode. Every 15th minutes a light show will go on for 10 seconds.</p> <p>The lightshow will be customized to the individual product/configuration.</p>
2-satellite interface	<p>Games will be selected and started on two satellites placed at the lower part of the spiders body. A simple interface supported by an intuitive sign with icons and QR codes will help guide the users through the various games and start the desired games.</p>

Additional games can be ordered at [PlayAlive](#).